



# Communication Systems II

---

Noise in CW modulation  
FM Modulation

# FM Receivers

- FM receivers are also of superheterodyne type.
- Typical frequencies for commercial FM radio are:
  - RF carrier range: 88-108 MHz
  - Mid band frequency of IF section: 10.7 MHz
  - IF bandwidth :0.2 MHz

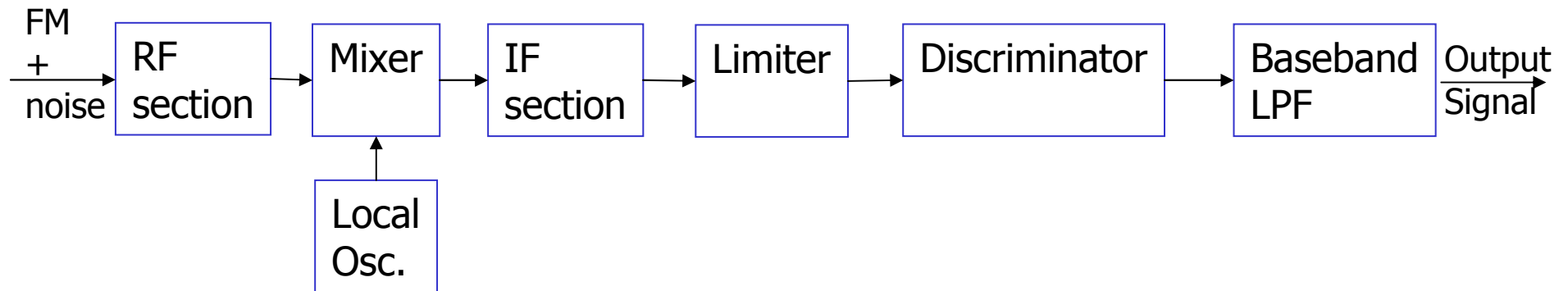

- The amplitude limiter removes amplitude variations by clipping the modulated wave at the IF section output.
- The resulting rectangular wave is rounded off by a bandpass filter which suppresses harmonics of the carrier frequency.



# FM Receivers

---

- The discriminator consists of two components
  - A slope network or differentiator with purely imaginary transfer function that varies linearly with frequency.
    - Produces a hybrid modulation of amplitude and frequency
  - An envelope detector that recovers the amplitude variation and thus reproduces the message signal.
- The post detection filter removes the out of band components of the noise at the discriminator output and thus keeps the output noise as small as possible.

# FM Receiver Model

- $W(t)$  is modeled as white Gaussian noise with zero mean and PSD of  $N_0/2$ .
- FM signal of center frequency  $f_c$  and  $BW = B_T$

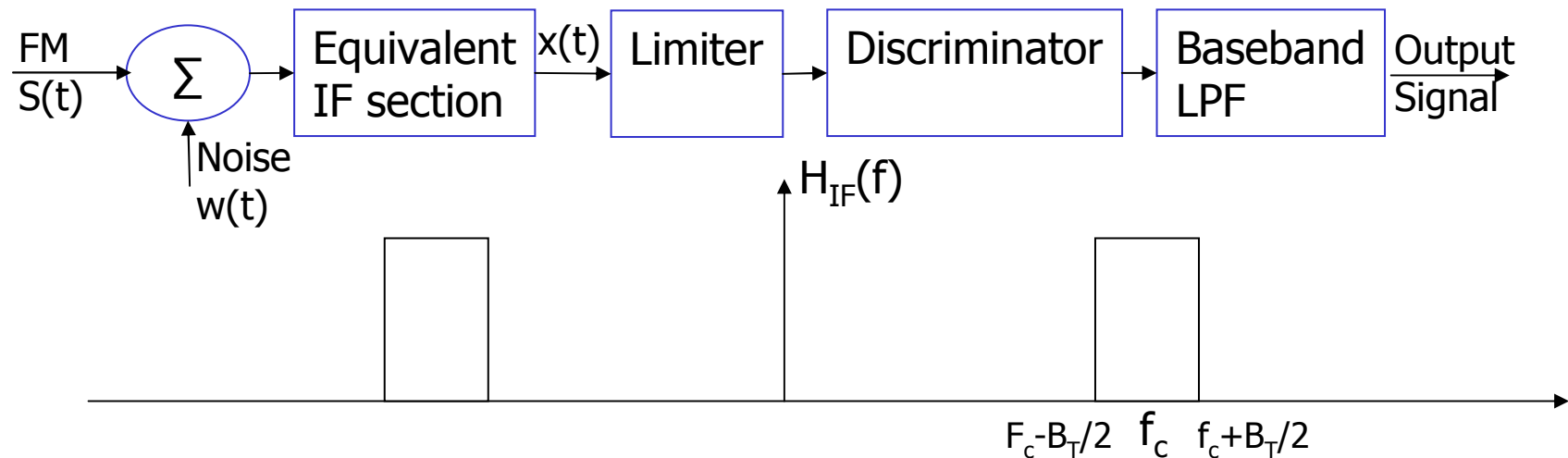

- IF filter is assumed IBPF with bandwidth  $B_T$ 
  - We can use the narrow band noise representation in terms of its inphase and quadrature components.



# Noise in FM reception

---

- The NBN at the IF output is defined as

$$n(t) = n_c(t) \cos(2\pi f_c t) - n_s(t) \sin(2\pi f_c t)$$

- Equivalently

$$n(t) = r(t) \cos(2\pi f_c t + \psi(t))$$

$$r(t) = \sqrt{n_c^2(t) + n_s^2(t)}$$

$$\psi(t) = \tan^{-1} \frac{n_s(t)}{n_c(t)}$$

- $r(t)$  is Rayleigh distributed and phase is uniformly distributed over  $2\pi$



# Noise in FM reception

---

- The FM signal at the IF output is

$$s(t) = A_c \cos\left(2\pi f_c t + 2\pi k_f \int_0^t m(t) dt\right)$$

$$\phi(t) = 2\pi k_f \int_0^t m(t) dt$$

$$s(t) = A_c \cos(2\pi f_c t + \phi(t))$$

- The total signal at the output of IF section is

- $X(t) = s(t) + n(t)$

$$x(t) = A_c \cos(2\pi f_c t + \phi(t)) + r(t) \cos(2\pi f_c t + \psi(t))$$

# Noise in FM reception

- Represent  $x(t)$  by means of a phasor diagram

$$x(t) = A_c \cos(2\pi f_c t + \phi(t)) + r(t) \cos(2\pi f_c t + \psi(t))$$

- The relevant phase  $\theta(t)$  can be calculated

$$\theta(t) = \phi(t) + \tan^{-1} \left\{ \frac{r(t) \sin(\psi(t) - \phi(t))}{A_c + r(t) \cos(\psi(t) - \phi(t))} \right\}$$

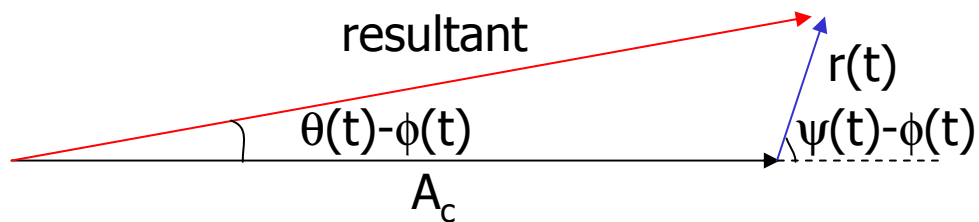



# Noise in FM reception

- Envelope of  $x(t)$  is not of interest to us
- The output of the ideal discriminator will be proportional to  $\theta'(t)/2\pi$

$$\theta(t) = \phi(t) + \tan^{-1} \left\{ \frac{r(t) \sin(\psi(t) - \phi(t))}{A_c + r(t) \cos(\psi(t) - \phi(t))} \right\}$$

$$\therefore \theta(t) \approx \phi(t) + \frac{r(t)}{A_c} \sin(\psi(t) - \phi(t))$$

$$\theta(t) \approx 2\pi k_f \int_0^t m(t) dt + \frac{r(t)}{A_c} \sin(\psi(t) - \phi(t))$$

- Assumptions
  - Carrier to noise ratio is large compared with unity

$$v(t) \text{ discriminator output} = \frac{1}{2\pi} \theta'(t)$$

$$v(t) = k_f m(t) + n_d(t)$$

$$\text{where } n_d(t) = \frac{1}{2\pi} \frac{d}{dt} \left\{ \frac{r(t)}{A_c} \sin(\psi(t) - \phi(t)) \right\}$$





# Noise in FM reception

---

- The noise component can be simplified further to

$$n_d(t) \approx \frac{1}{2\pi} \frac{d}{dt} \left\{ \frac{r(t)}{A_c} \sin(\psi(t)) \right\}$$

however

$$n_s(t) = r(t) \sin(\psi(t))$$

$$n_d(t) \approx \frac{1}{2\pi} \frac{d}{dt} \left\{ \frac{n_s(t)}{A_c} \right\}$$

- The power in the output message is  $k_f^2 P$  where  $p$  is power in transmitted message
- Required to find the power in the noise component
  - Derivative in time  $\rightarrow j2\pi f$  in frequency

$$\therefore S_{n_d}(f) = \frac{f^2}{A_c^2} S_{n_s}(f)$$

# Noise in FM reception

- With the Equivalent IF filter has ideal response.
  - It follows that the narrow-band noise  $n(t)$  will have a PSD similar in shape to the transfer function of the IF filter
  - Therefore the quadrature component of the NBN will have the ideal low pass characteristic.
  - The corresponding PSD of  $n_d$  will be

$$\therefore S_{n_d}(f) = \frac{f^2}{A_c^2} S_{n_s}(f)$$

$$S_{n_d}(f) = \begin{cases} \frac{N_o f^2}{A_c^2}, & |f| \leq \frac{B_T}{2} \\ 0, & \text{elsewhere} \end{cases}$$

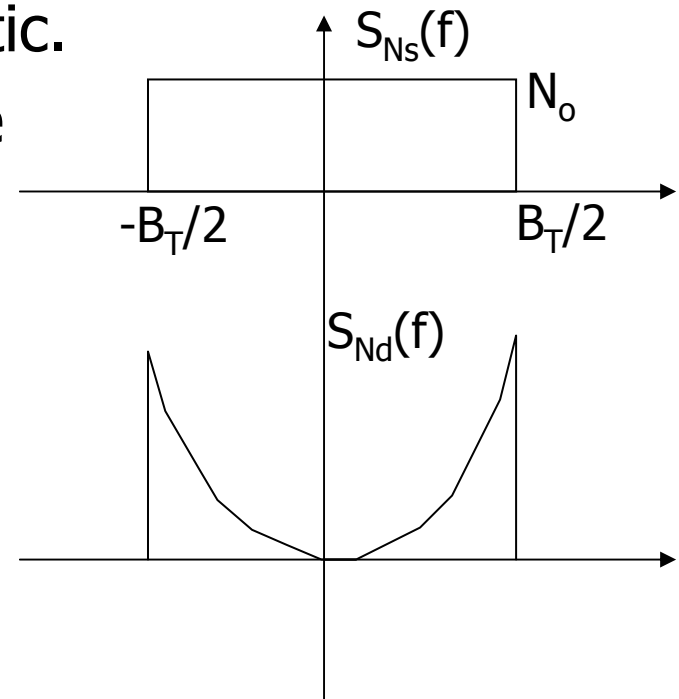

# Noise in FM reception

- The discriminator output is followed by a low pass filter with bandwidth equal to the bandwidth of the message  $W$ .
  - $W \gg B_T/2$
  - Therefore the noise component  $n_d(t)$  will have rejection region.
  - The corresponding PSD of  $n_d$  after LPF will be

$$S_{n_{\text{out}}}(f) = \begin{cases} \frac{N_o f^2}{A_c^2}, & |f| \leq W \\ 0, & \textit{elsewhere} \end{cases}$$

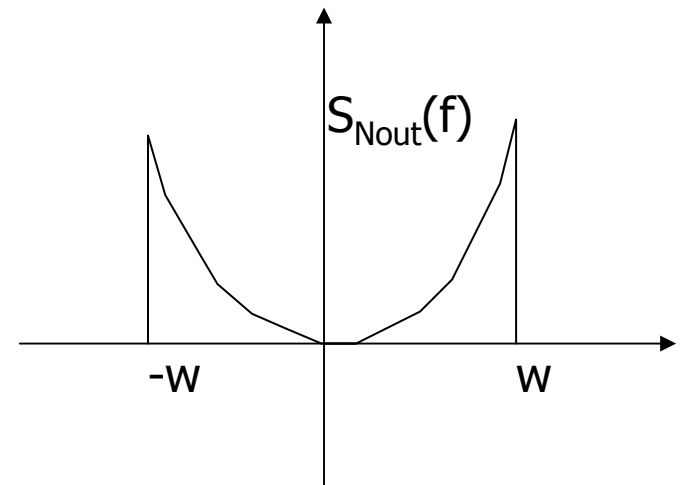



# Noise in FM reception

- The average output noise power is determined by integrating the PSD  $S_{\text{nout}}$  from  $-W$  to  $W$

$$\begin{aligned} \text{average power of output noise} &= \frac{N_o}{A_c^2} \int_{-W}^W f^2 df \\ &= \frac{2N_o}{3A_c^2} W^3 \end{aligned}$$

- Note that the average output noise power is inversely proportional to the carrier power  $A_c^2/2$

$$SNR_{c,FM} = \frac{A_c^2}{2N_o W}$$

$$SNR_{o,FM} = \frac{3A_c^2 k_f^2 P}{2N_o W^3}$$

$$\text{Figure of Merit} = \frac{3k_f^2 P}{W^2}$$



# Single tone modulation example

---

- Consider the case of single tone modulation with maximum frequency deviation  $\Delta f$ .

$$s(t) = A_c \cos(2\pi f_c t + \frac{\Delta f}{f_m} \sin(2\pi f_m t))$$

$$m(t) = \frac{\Delta f}{k_f} \cos(2\pi f_m t)$$

$$P = \frac{\Delta f^2}{2k_f^2}$$

$$SNR_{o,FM} = \frac{3A_c^2 \Delta f^2}{4N_o W^3} = \frac{3A_c^2}{4N_o W} \beta^2$$

$$F_oM = \frac{3}{2} \beta^2$$



# Narrow Band FM

- NBFM  $\rightarrow \beta < 1/3$

$$s_{NBFM}(t) = A_c \cos(2\pi f_c t) - A_c \sin(2\pi f_c t) \left[ k_f \int_0^t m(t) dt \right]$$

$$P = \frac{A_c^2}{2}$$

$$R_{s_{NBFM}}(\tau) = \frac{A_c^2}{2} \cos(2\pi f_c \tau) + \frac{A_c^2}{2} \cos(2\pi f_c \tau) R_{\phi_m}(\tau)$$

$$\phi_m = \begin{cases} k_p m(t), PM \\ k_f \int_0^t m(t) dt, FM \end{cases}$$

$$S_m(f) = \begin{cases} k_p^2 S_m(f) \\ \frac{k_f^2 S_m(f)}{(2\pi f)^2} \end{cases}$$

- Received signal

$$x(t) = A_c \cos(2\pi f_c t) - A_c \sin(2\pi f_c t) \left[ k_f \int_0^t m(t) dt \right] + w(t)$$

$$SNR_{c,NBFM} = \frac{A_c^2}{2N_0 W_{ch}}$$

after IF section

$$SNR_{NBFM} = \frac{A_c^2}{2N_0 2W}$$

$$P = \frac{A_c^2}{2}$$

$$SNR_{o,FM} = \frac{3A_c^2 k_f^2 P}{2N_o W^3}$$

$$\text{Figure of Merit} = \frac{3k_f^2 P}{W^2} = \frac{3}{2} \beta^2, \beta \ll 1$$

# FM Noise Characteristic

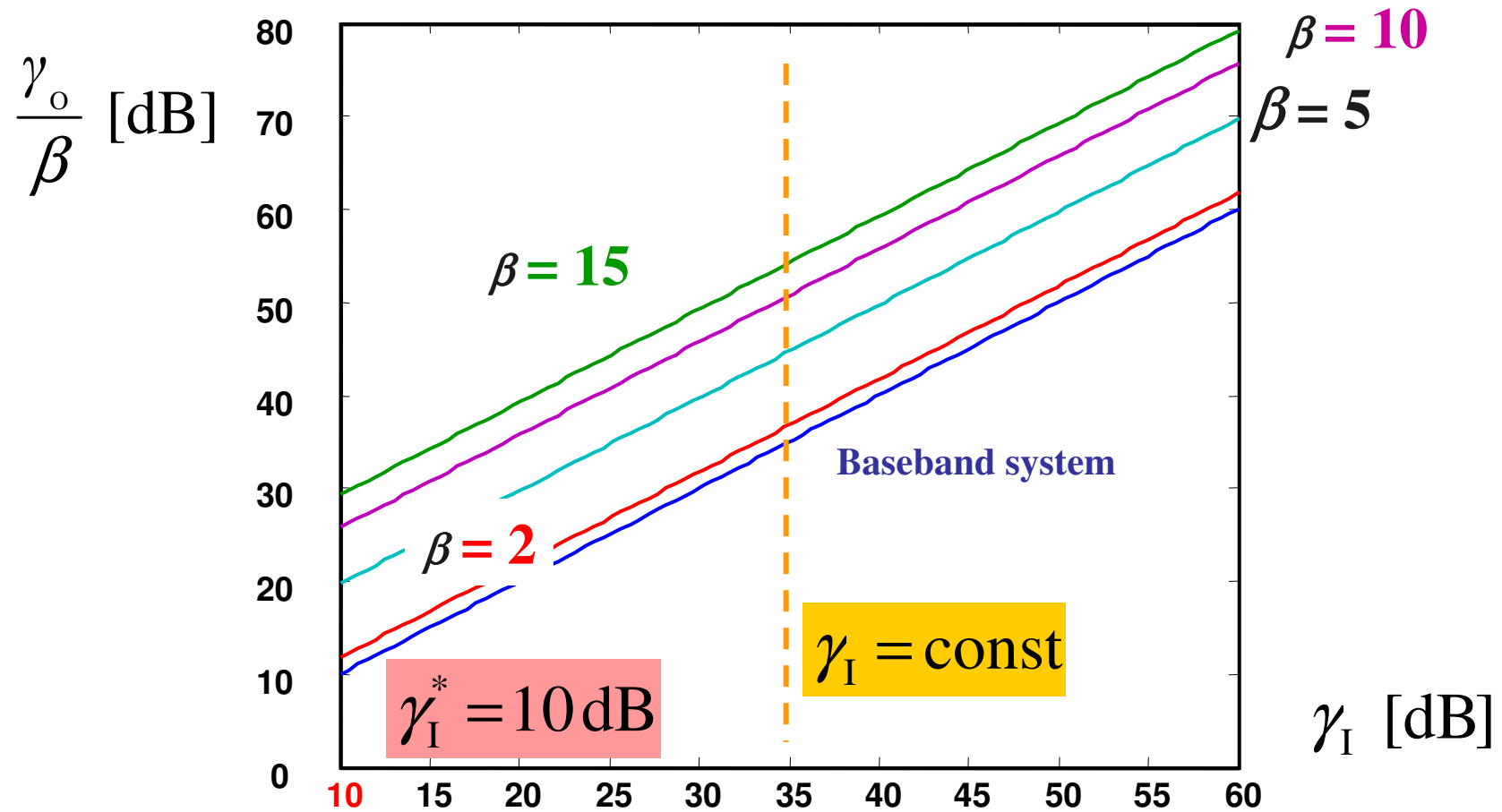

# What if the noise is bigger than the signal

- Represent  $x(t)$  by means of a phasor diagram

$$x(t) = A_c \cos(2\pi f_c t + \phi(t)) + r(t) \cos(2\pi f_c t + \psi(t))$$

- $r(t) \gg A_c$
- The relevant phase  $\theta(t)$  can be calculated

$$\theta(t) = \psi(t) + \tan^{-1} \left\{ \frac{A_c \sin(\phi(t) - \psi(t))}{r(t) + A_c \cos(\phi(t) - \psi(t))} \right\}$$

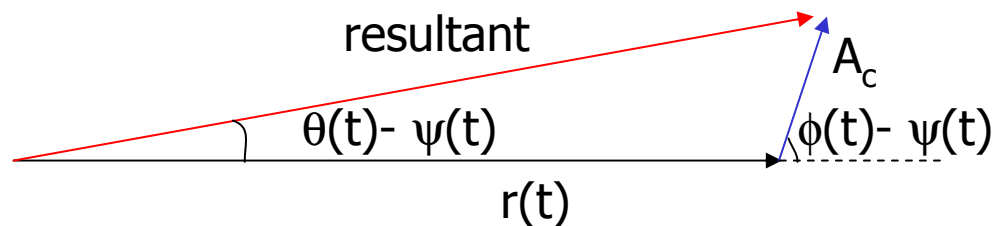



# Noise >>> FM reception

- Envelope of  $x(t)$  is not of interest to us
- The output of the ideal discriminator will be proportional to  $\theta'(t)/2\pi$

$$\theta(t) = \psi(t) + \tan^{-1} \left\{ \frac{A_c \sin(\phi(t) - \psi(t))}{r(t) + A_c \cos(\phi(t) - \psi(t))} \right\}$$

$$\therefore \theta(t) \approx \psi(t) + \frac{A_c}{r(t)} \sin(\phi(t) - \psi(t))$$

- Assumptions

- Carrier to noise ratio is small compared with unity

$$\theta(t) \approx \psi(t) + \frac{A_c}{r(t)} \sin(2\pi k_f \int_0^t m(t) dt - \psi(t))$$

- **V(t) is complete noise**

$$v(t) \text{ discriminator output} = \frac{1}{2\pi} \theta'(t)$$

- No detection  $\rightarrow$  FM threshold effect
- SNR > 1

$$v(t) = \frac{d\psi(t)}{2\pi dt} + n_d(t)$$

$$\text{where } n_d(t) = \frac{1}{2\pi} \frac{d}{dt} \left\{ \frac{A_c}{r(t)} \sin(2\pi k_f \int_0^t m(t) dt - \psi(t)) \right\}$$

# Pre-emphasis and De-emphasis in FM

- The PSD of the noise at the receiver output has a square law dependence on the operating frequency

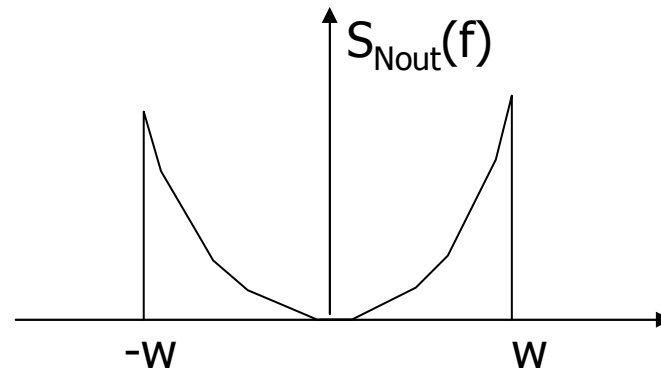

- The PSD of a typical message source (audio, video) has the following general shape
- The PSD falls significantly at high frequencies while the noise PSD increases rapidly with frequency

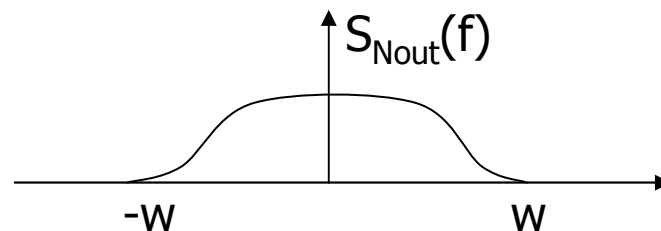

# Pre-emphasis and De-emphasis in FM

- One way to improve the noise performance of the system is to slightly reduce the bandwidth of the post detection low pass filter so to reject large amount of noise power → **unacceptable**
- Another method is to use a pre-emphasis at the transmitter and a de-emphasis at the receiver as shown in the following figure

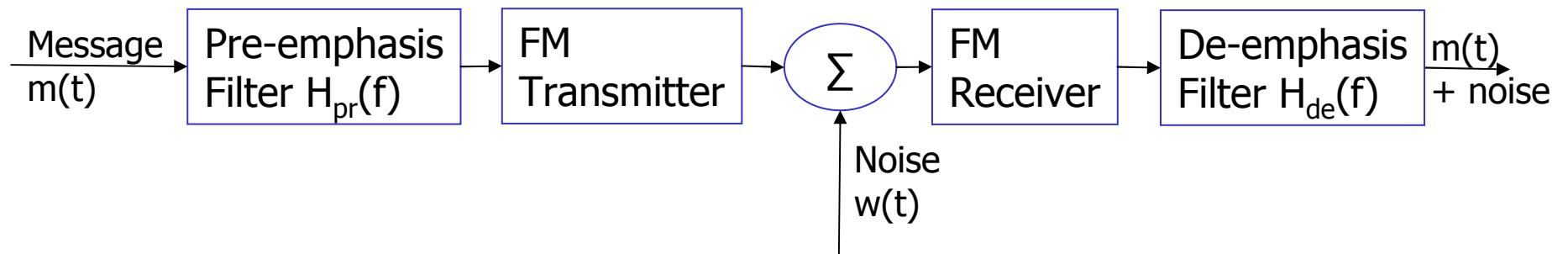



# Pre-emphasis and De-emphasis in FM

---

- In this method, emphasize the high frequency components of the message signal prior to modulation in the transmitter.
- The low frequency and the high frequency portions of the message are equalized to occupy the whole frequency band allocated to it.
- At the discriminator output, inverse process is performed to de-emphasize the high frequency components to restore the original signal power distribution of the message.
  - The high frequency portion of the noise will be reduced thus increasing the output signal to noise ratio of the system



# Pre-emphasis and De-emphasis in FM

---

- In order to produce an undistorted version of the original message at the receiver output, the pre-emphasis and de-emphasis must ideally have transfer function that is inverse to each other

$$H_{de}(f) = \frac{1}{H_{pe}(f)}, \quad -W \leq f \leq W$$

- This makes the message power independent of this operation.
- For the noise component after the discriminator

$$S_{n_d}(f) = \begin{cases} \frac{N_o f^2}{A_c^2}, & |f| \leq \frac{B_T}{2} \\ 0, & \textit{elsewhere} \end{cases}$$

# Pre-emphasis and De-emphasis in FM

- Thus the modified PSD of the noise at the de-emphasis output is equal to  $|H_{de}(f)|^2 S_{n_d}(f)$

- Since the final LPF has  $BW = W \ll B_T/2$

Av. o/p noise power

$$\text{with de - emphasis} = \frac{N_o}{A_c^2} \int_{-w}^w f^2 |H_{de}(f)|^2 df$$

- The improvement in o/p SNR due to de-emphasis is

$$D = \frac{\text{Average o/p noise power without emphasis}}{\text{Average o/p noise power with emphasis}}$$

$$D = \frac{2W^3}{3 \int_{-w}^w f^2 |H_{de}(f)|^2 df}$$

# Noise characteristics

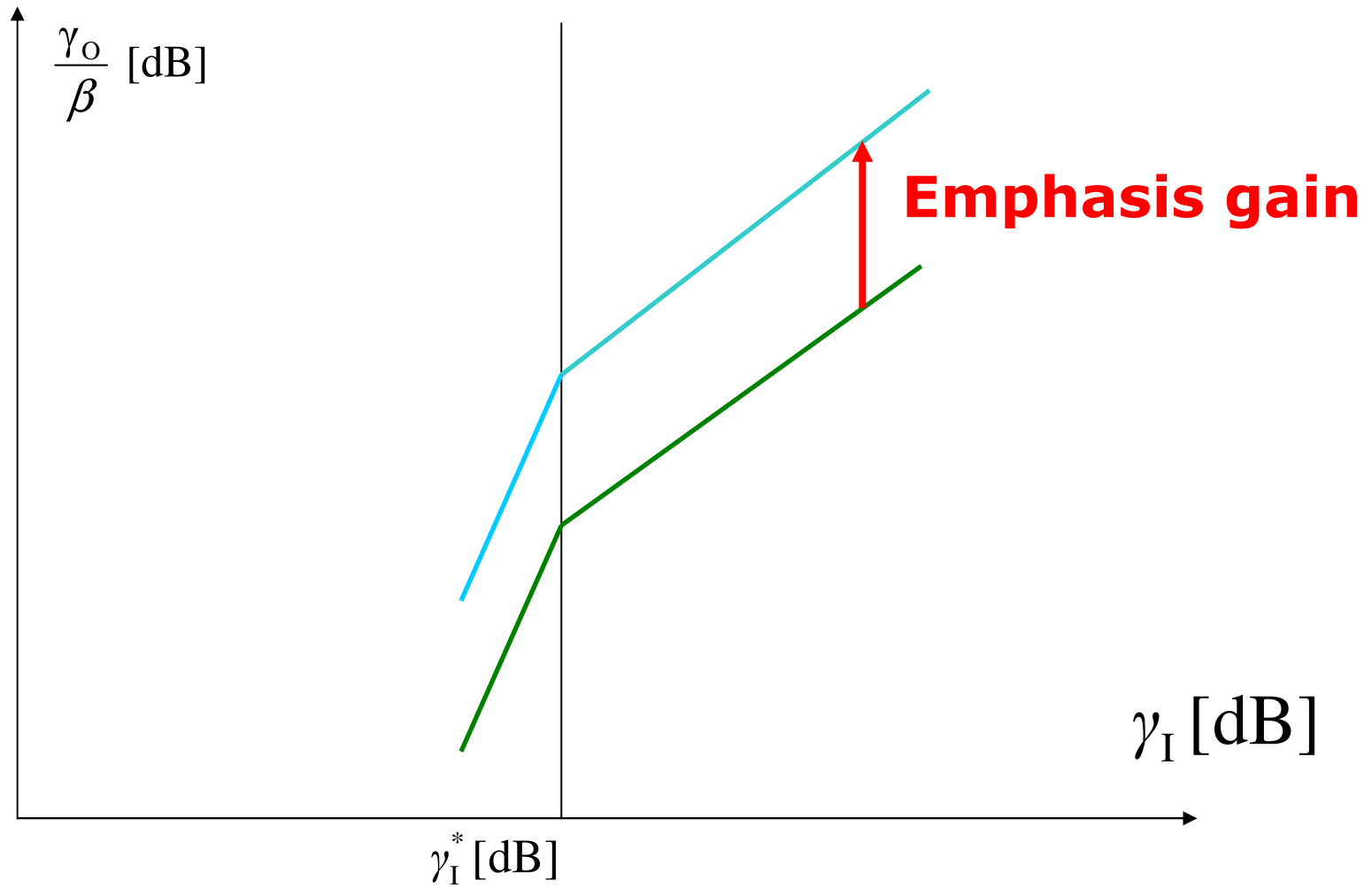

# FM preemphases and deemphases filters

- FM related noise emphases can be suppressed by *pre-distortion* and post detection filters (preemphases and deemphases filters):

**receiver filter**

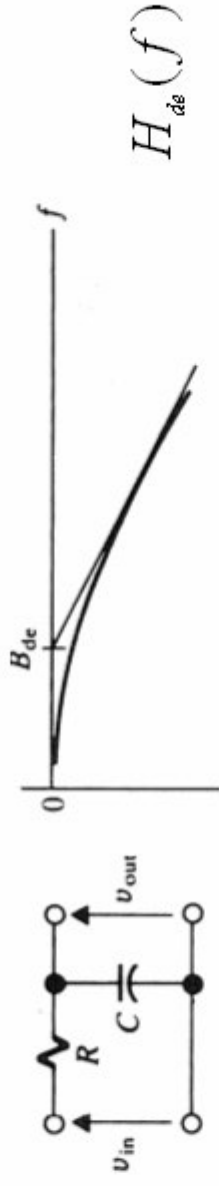

**transmitter filter**

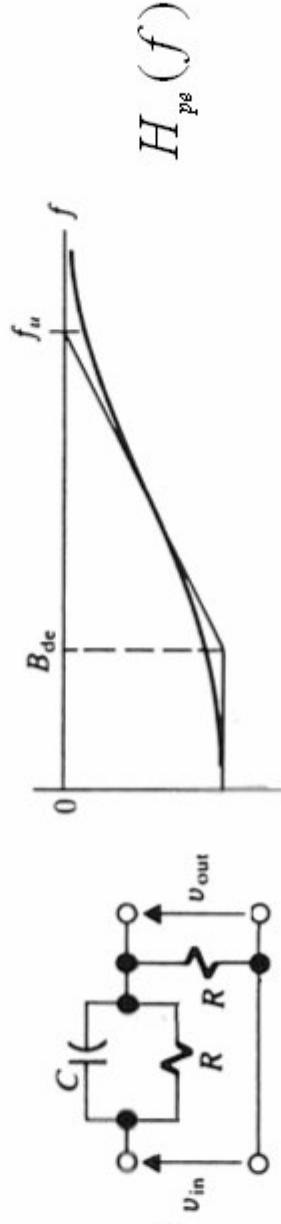

$$H_{de}(f) = [1 + j(f / B_{de})]^{-1} \approx \begin{cases} 1, & |f| \ll B_{de} \\ B_{de} / (jf), & |f| \gg B_{de} \end{cases} \quad \text{LPF}$$

$$H_{pre}(f) = [1 + j(f / B_{de})] \approx \begin{cases} j(f / B_{de}), & f_u > |f| > B_{de} \\ 1, & |f| \gg f_u \end{cases} \quad \text{HPF}$$