

CC231

Introduction to Networks

Dr. Ayman A. Abdel-Hamid

College of Computing and Information Technology

Arab Academy for Science and Technology

Physical Media

Outline

- Physical Media

Physical Media ^{1/6}

- **physical link**: transmitted data bit propagates across link
 - *guided media*
 - ✓ signals propagate in solid media: copper, coax, and fiber
 - *unguided media*
 - ✓ signals propagate freely, e.g., radio waves
- **Guided media → Twisted-Pair (TP)**
 - Two insulated copper wires
 - ✓ Category 3: traditional phone wires, 10 Mbps Ethernet
 - ✓ Category 5: 100Mbps Ethernet
 - ✓ Two varieties: UTP (Unshielded TP) and STP (Shielded TP)

Physical Media 2/6

• Guided media → Twisted-Pair (TP)

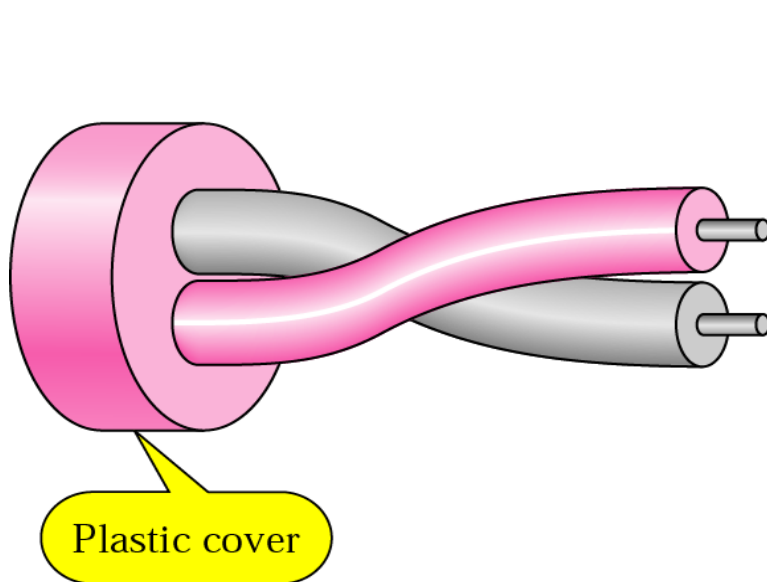
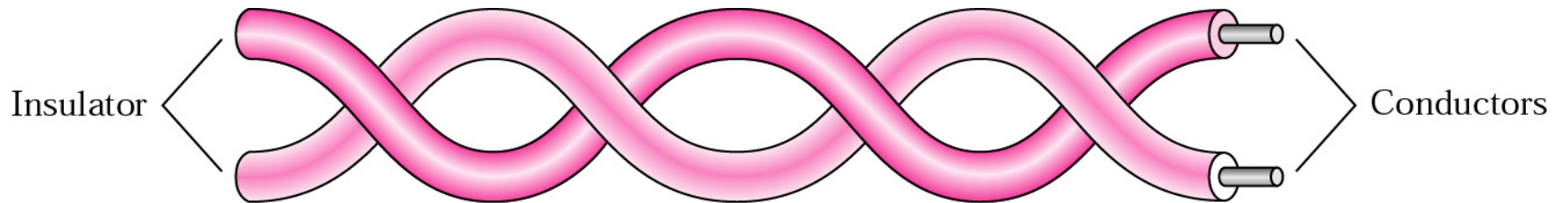

a. UTP

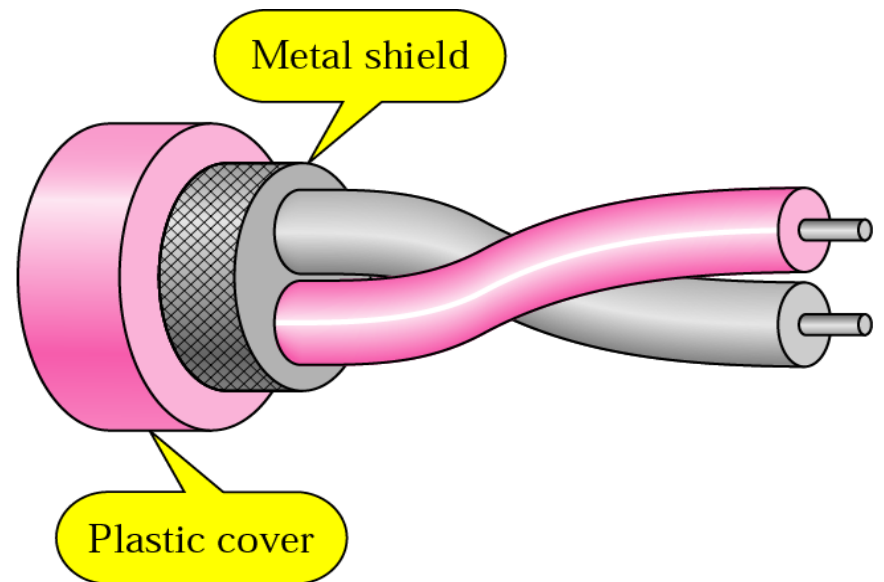

b. STP

Physical Media ^{3/6}

- Guided media → Twisted-Pair (TP)

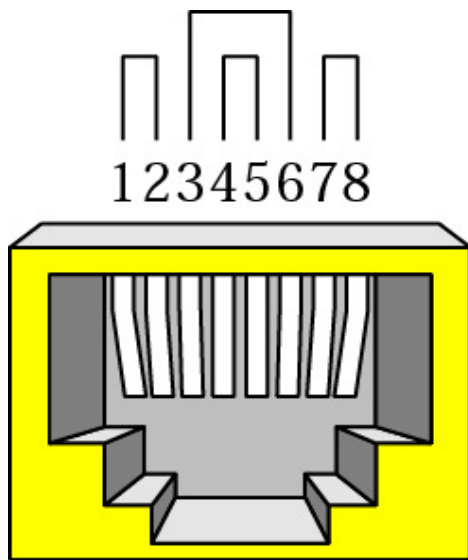

RJ-45 Female

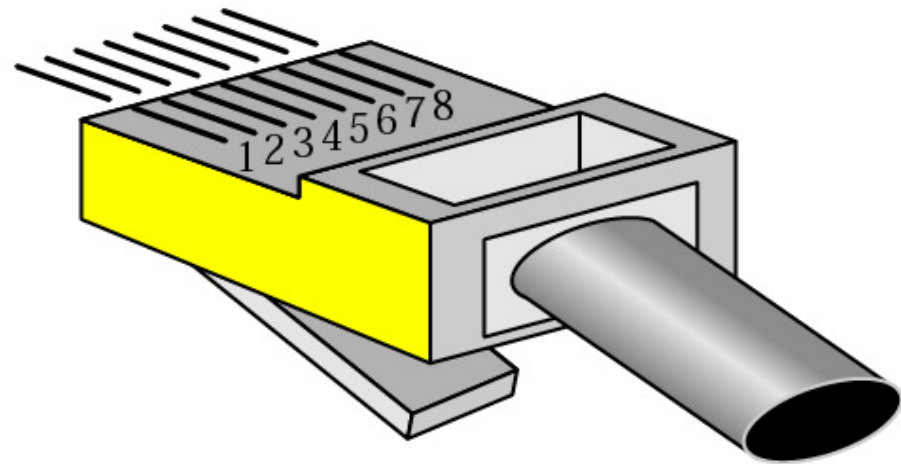

RJ-45 Male

UTP Connector (RJ stands for Registered Jack)

Physical Media 4/6

• Guided media → Coaxial Cable

- wire (signal carrier) within a wire (shield)
 - ✓ baseband: single channel on cable
 - ✓ broadband: multiple channels on cable
- Bidirectional
- common use in 10Mbps Ethernet

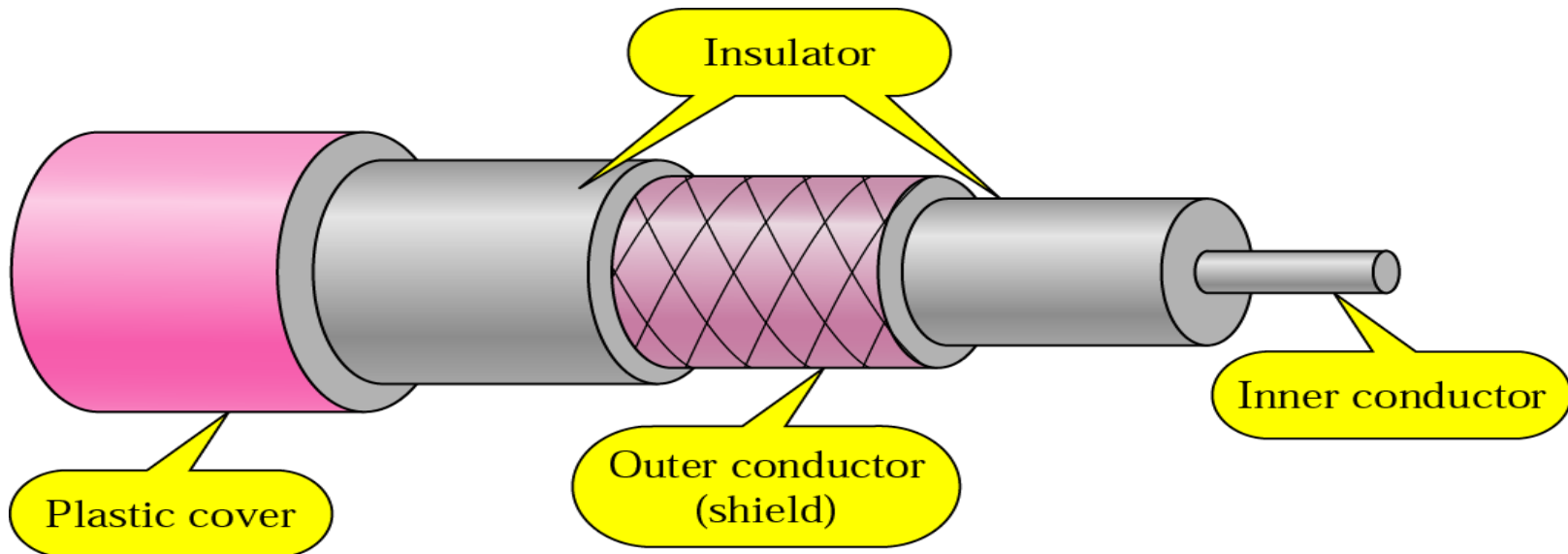

Physical Media 5/6

• Guided media → Fiber-Optic

- glass fiber carrying light pulses
- high-speed operation
 - ✓ 100Mbps Ethernet
 - ✓ high-speed point-to-point transmission (e.g., 5 Gbps)
- low error rate

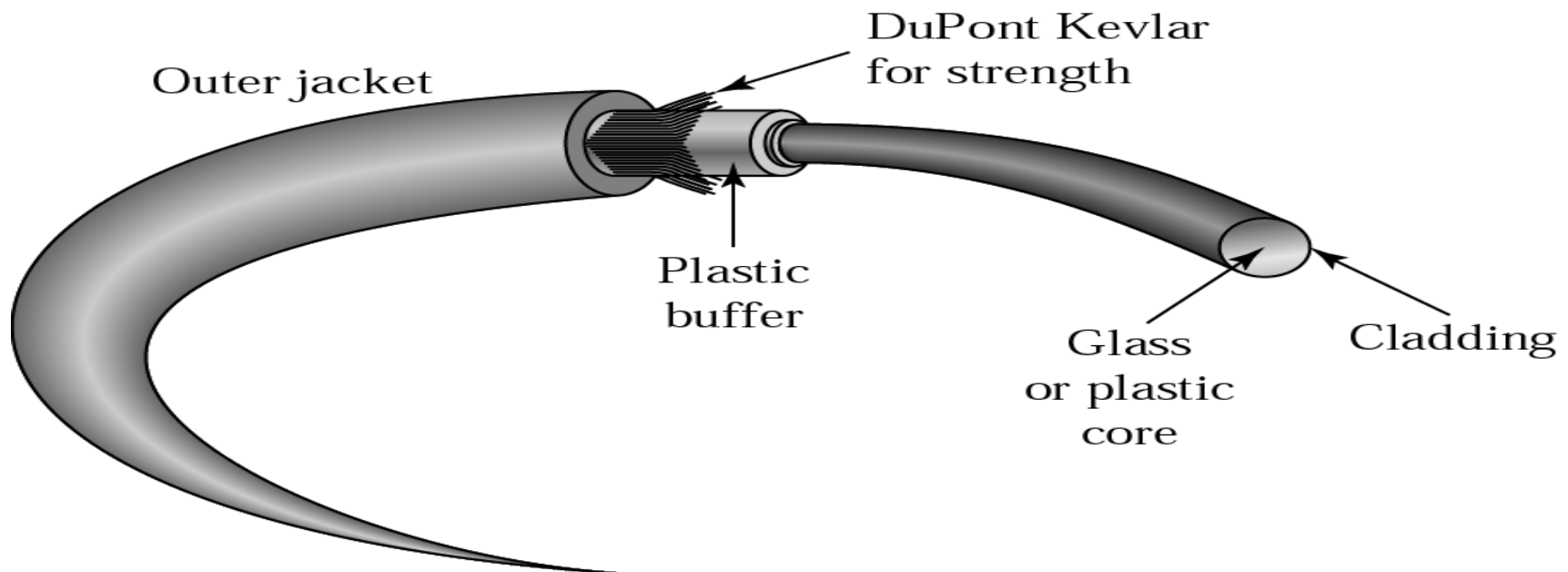

Physical Media 6/6

- **Unguided media → Wireless**

- signal carried in electromagnetic spectrum (bidirectional)
- propagation environment effects: reflection, obstruction by objects, and interference

- **Wireless link types**

- ✓ Infrared (300 GHz to 400 THz)
- ✓ Radio and microwave (3 KHz to 300 GHz)
 - ❑ Radio: multicast communication such as radio, television, and paging systems
 - ❑ Microwave: unicast communication such as cellular telephones, satellite, and wireless LANs
- ✓ Wireless LAN: 2Mbps, 11Mbps, and 54 Mbps
- ✓ Satellite
 - ❑ up to 50Mbps channel (or multiple smaller channels)
 - ❑ 270 msec end-to-end delay
 - ❑ geosynchronous (GEO) versus LEO satellites