

# Information Systems Security

**Dr. Ayman Abdel-Hamid**

College of Computing and Information Technology

Arab Academy for Science & Technology and  
Maritime Transport

**Firewalls**

# Outline

- Firewalls

- Types

- Configurations

- Access control

- Trusted systems

# Introduction

- seen evolution of information systems
- now everyone wants to be on the Internet
- and to interconnect networks
- has persistent security concerns
  - can't easily secure every system in org.
- need "harm minimization"
- a **Firewall** usually part of this

# What is a Firewall?

- a **choke point** of control and monitoring
- interconnects networks with differing trust
- imposes restrictions on network services
  - only authorized traffic is allowed
- auditing and controlling access
  - can implement alarms for abnormal behavior
- is itself immune to penetration
- provides **perimeter defence**

# Firewall Techniques for Access Control

- **Service Control**
  - Types of internet services accessed inbound or outbound
- **Direction Control**
  - Direction in which particular service requests may be initiated and allowed to flow through the firewall
- **User Control**
  - Controls access to service according to which user is attempting to access it
- **Behaviour Control**
  - How particular services are used

# Firewall Limitations

- cannot protect from attacks bypassing it
  - e.g. utility modems, trusted organisations, trusted services (eg SSL/SSH)
- cannot protect against internal threats
  - e.g. disgruntled employee
- cannot protect against transfer of all virus infected programs or files
  - because of huge range of O/S & file types

# Firewalls – Packet Filters

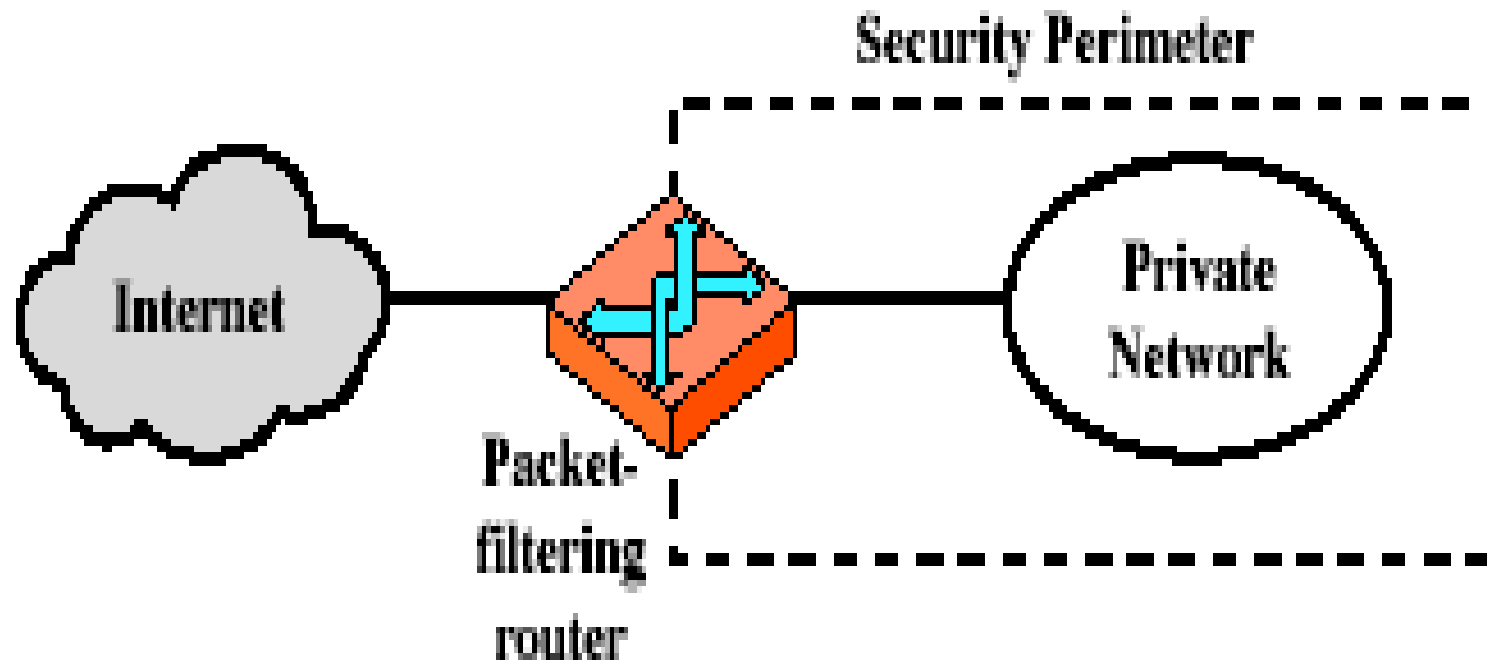

**(a) Packet-filtering router**

# Firewalls – Packet Filters

- foundation of any firewall system
- examine each IP packet in both directions (no context) and permit or deny according to rules
  - Source IP address
  - Destination IP address
  - Source and destination ports
  - IP protocol field
  - Interface
- If no rule match → possible default policies
  - that not expressly permitted is prohibited
  - that not expressly prohibited is permitted

# Firewalls – Packet Filters

Table 20.1 Packet-Filtering Examples

**A**

action	ourhost	port	theirhost	port	comment
block	*	*	SPIGOT	*	we don't trust these people
allow	OUR-GW	25	*	*	connection to our SMTP port

**B**

action	ourhost	port	theirhost	port	comment
block	*	*	*	*	default

**C**

action	ourhost	port	theirhost	port	comment
allow	*	*	*	25	connection to their SMTP port

**D**

action	src	port	dest	port	flags	comment
allow	{our hosts}	*	*	25		our packets to their SMTP port
allow	*	25	*	*	ACK	their replies

**E**

action	src	port	dest	port	flags	comment
allow	{our hosts}	*	*	*		our outgoing calls
allow	*	*	*	*	ACK	replies to our calls
allow	*	*	*	>1024		traffic to nonservers

# Attacks on Packet Filter Firewalls

- **IP address spoofing**
  - fake source address to be trusted (address of internal host)
  - *add filters on router to block (discard packet with an inside source address if packet arrives on external interface)*
- **source routing attacks**
  - attacker sets a route other than default
  - *block source routed packets*
- **tiny fragment attacks**
  - split header info over several tiny packets (force TCP header information into a separate packet fragment)
  - *either discard or reassemble before check*

# Firewalls – Stateful Packet Filters

- Traditional packet filter does not take into consideration higher layer context
- examine each IP packet in context
  - keeps tracks of client-server sessions
  - checks each packet validly belongs to one
- better able to detect bogus packets out of context

# Firewalls - Application Level Gateway (or Proxy)

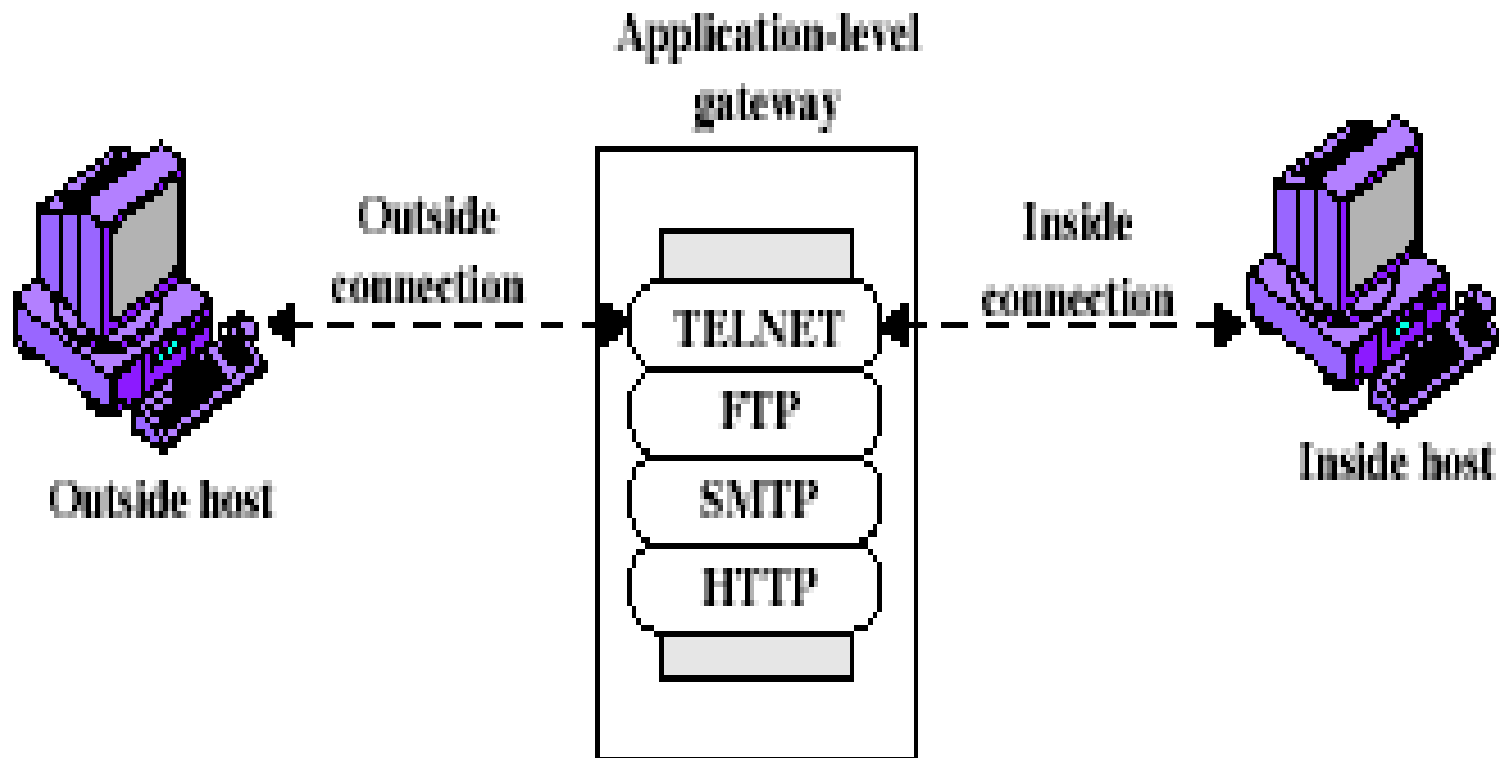

**(b) Application-level gateway**

# Firewalls - Application Level Gateway (or Proxy)

- use an *application specific* gateway / proxy
- has full access to protocol
  - user requests service from proxy
  - proxy validates request as legal
  - then actions request and returns result to user
- need separate proxies for each service
  - some services naturally support proxying
  - others are more problematic
  - custom services generally not supported

# Firewalls - Circuit Level Gateway

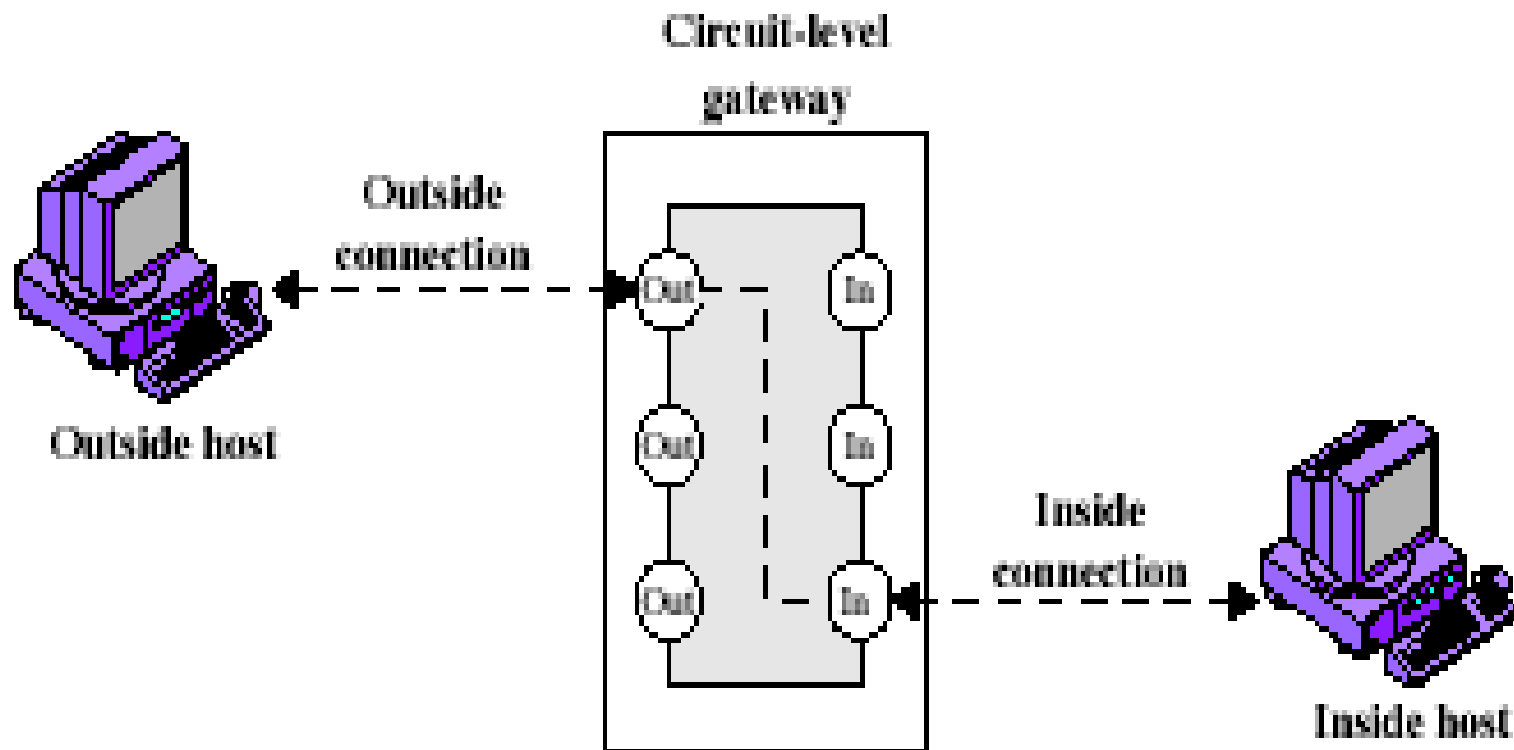

(c) Circuit-level gateway

# Firewalls - Circuit Level Gateway

- relays two TCP connections
- imposes security by limiting which such connections are allowed
- once created usually relays traffic without examining contents
- typically used when trust internal users by allowing general outbound connections

# Bastion Host

- highly secure host system
- potentially exposed to "hostile" elements
- hence is secured to withstand this
- may support 2 or more Net. connections
- may be trusted to enforce trusted separation between network connections
- runs circuit / application level gateways
- or provides externally accessible services

# Firewall Configurations

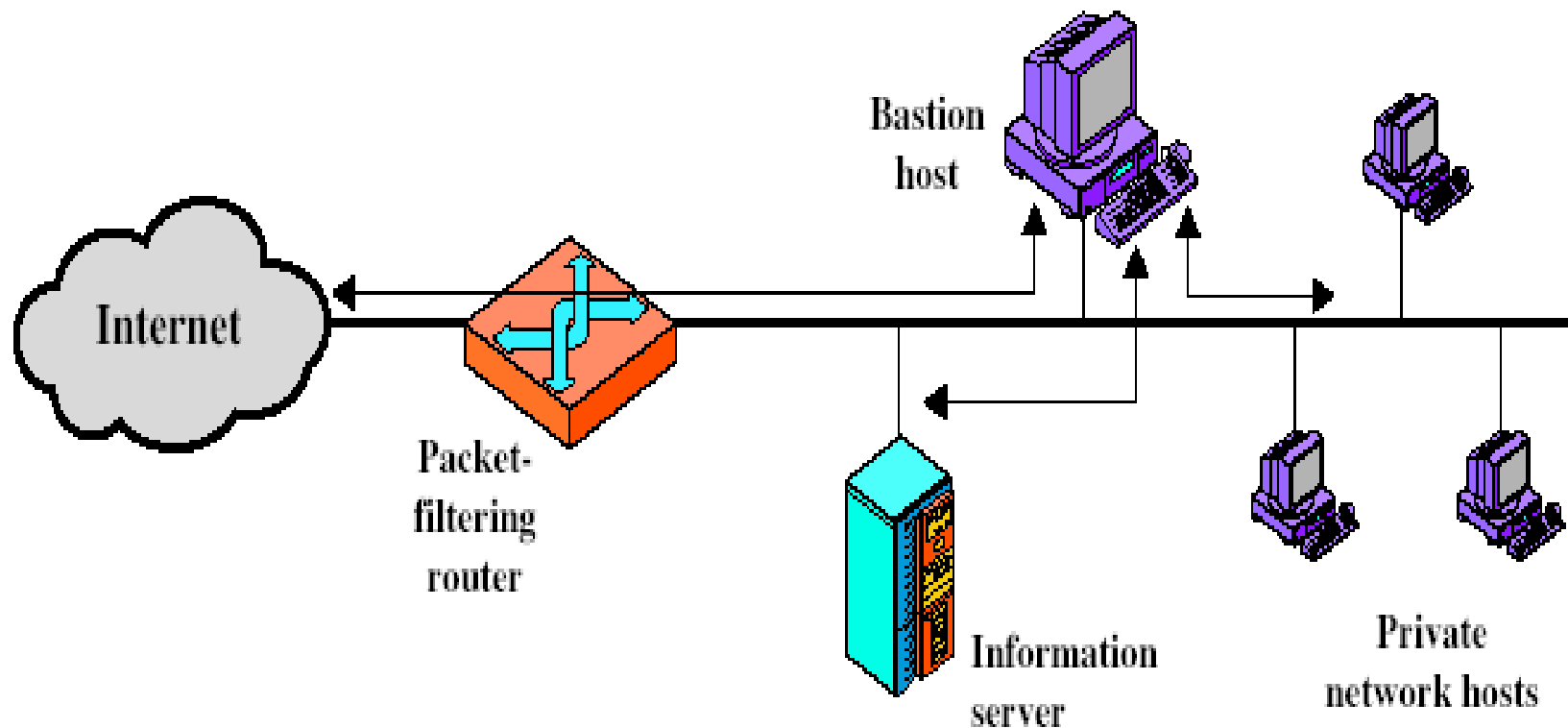

(a) Screened host firewall system (single-homed bastion host)

# Screened Host Firewall, Single-homed Bastion

- *For traffic from the Internet*, only IP packets destined for the bastion host are allowed in
- *For traffic from internal network*, only IP packets from bastion host are allowed out
- Bastion host performs authentication and proxy functions
- Provides flexibility in allowing direct internet access (for a web server for example)
- **Problem**: if packet-filtering router compromised, traffic could flow directly through router

# Firewall Configurations

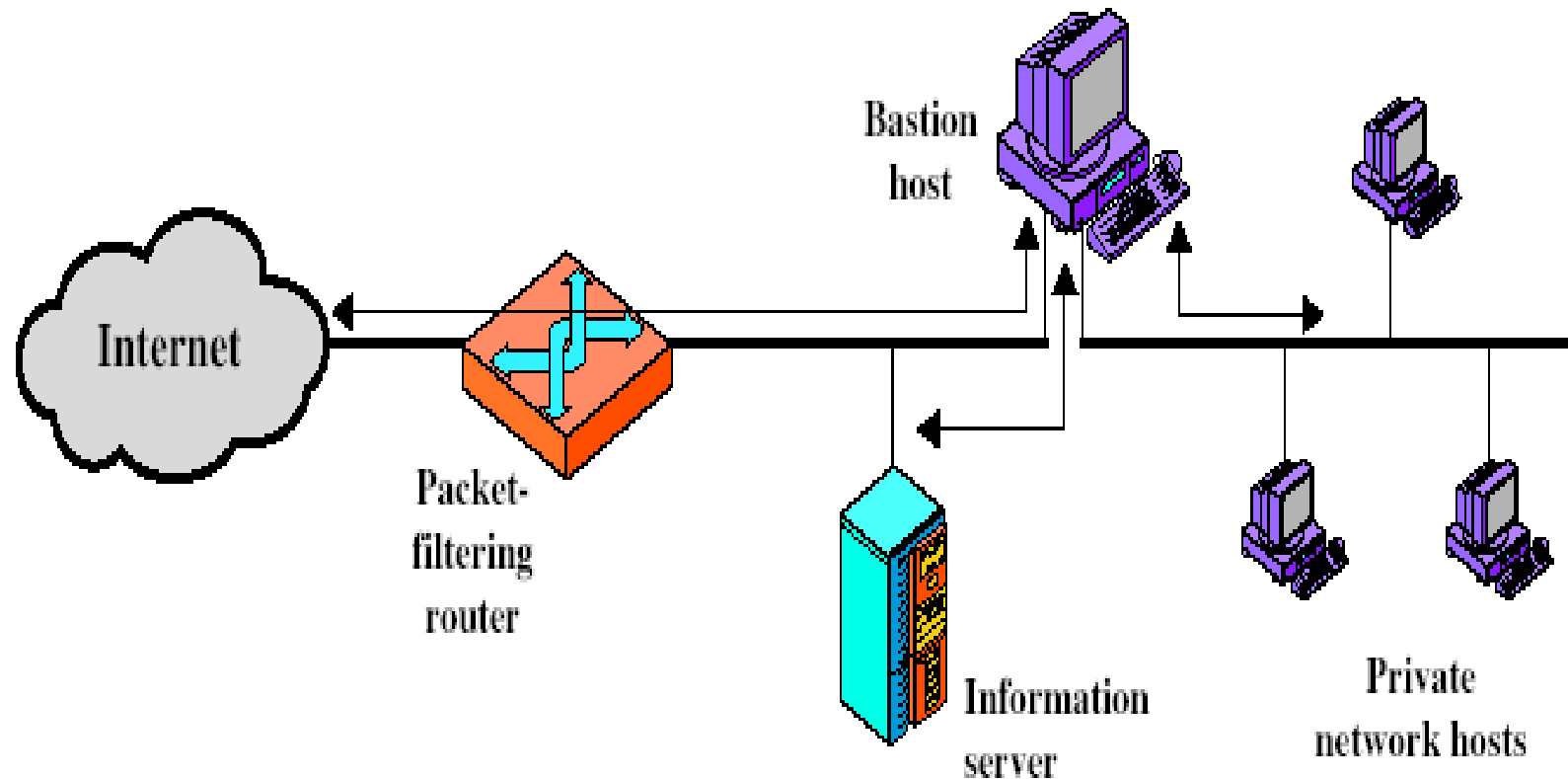

(b) Screened host firewall system (dual-homed bastion host)

# Firewall Configurations

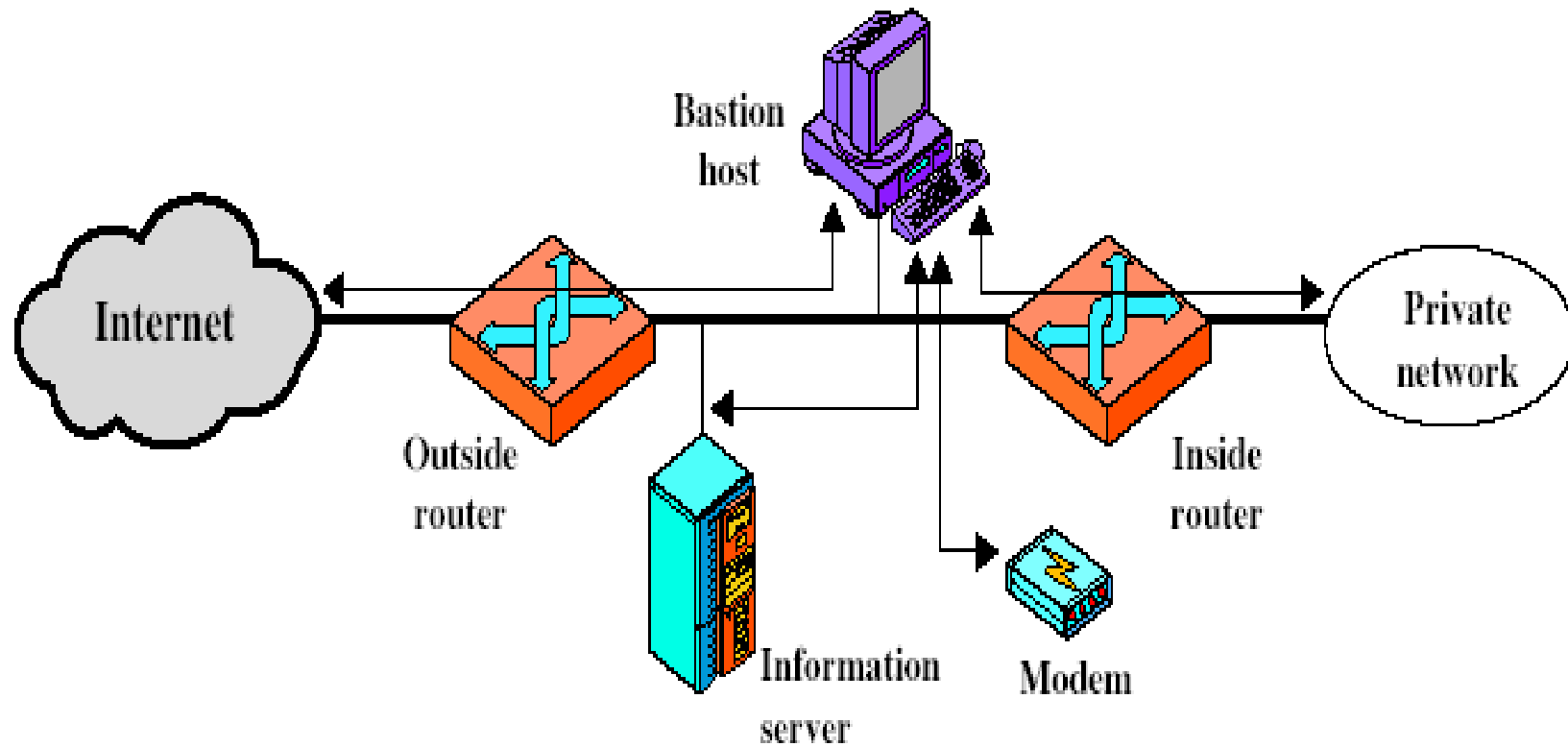

(c) Screened-subnet firewall system

# Screened-subnet firewall system

- 3 levels of defence
- Outside router advertises only existence of screened subnet to the Internet (Internal network invisible)
- Inside router advertises existence of screened subnet to the internal network